

OTHER VALVES AND VALVES PARTS

MODEL CGL02 / CGL03

Cryogenic Globe Valve

Socket Weld

Butt Weld



Maximum Pressure	PN50
Temperature Rating	-196°C ~ +65°C
Material	CF8M
Seat	PCTFE
Additional Features	BS 6364: 1984 Cryogenic Test Approval

MATERIALS LIST

NO.	PART NAME	Q'TY	MATERIAL
1	BODY	1	CF8M
2	CAP	1	CF8M
3	PIPE LINER	1	SUS316
4	PLUG STEM	1	SUS316
5	BRASS BUSHING	1	BRASS
6	PLUG	1	BRASS
7	SEAT	1	PCTFE
8	SEAT RING	1	SIGMA511
9	SNALINK	1	SUS420
10	BALL	10	SUS304
11	SEAT NUT	1	SUS304
12	BONNET NUT	1	SUS304
13	NUT	1	SUS304
14	GLAND	1	BRASS
15	V-RING PACKING	3	TFM1600
16	O-RING	1	NBR
17	WASHER	2"	BRASS
18	SPRING	1	SUS304
19	HANDLE WHEEL	1	DUCTILE IREN
20	NUT	1	SUS304
21	WASHER	1	SUS304
22	BOOT	1	SI
23	WASHER	1	BRASS
24	BUNG GASKET	1	PTFE
25	BOLT	4~6	SUS304

DIMENSIONS (mm)

SIZE	A	ØB	ØC	D	ØE	ØF	G
1/2"	68	16	24	285	80	21	9.5
1"	92	27	35	287.5	100	34	12
1 1/2"	121	41.5	50.5	297	125	49	12.5
2"	146	53	62	298	125	61.5	11
2 1/2"	178	67	77	364.6	160	74	15

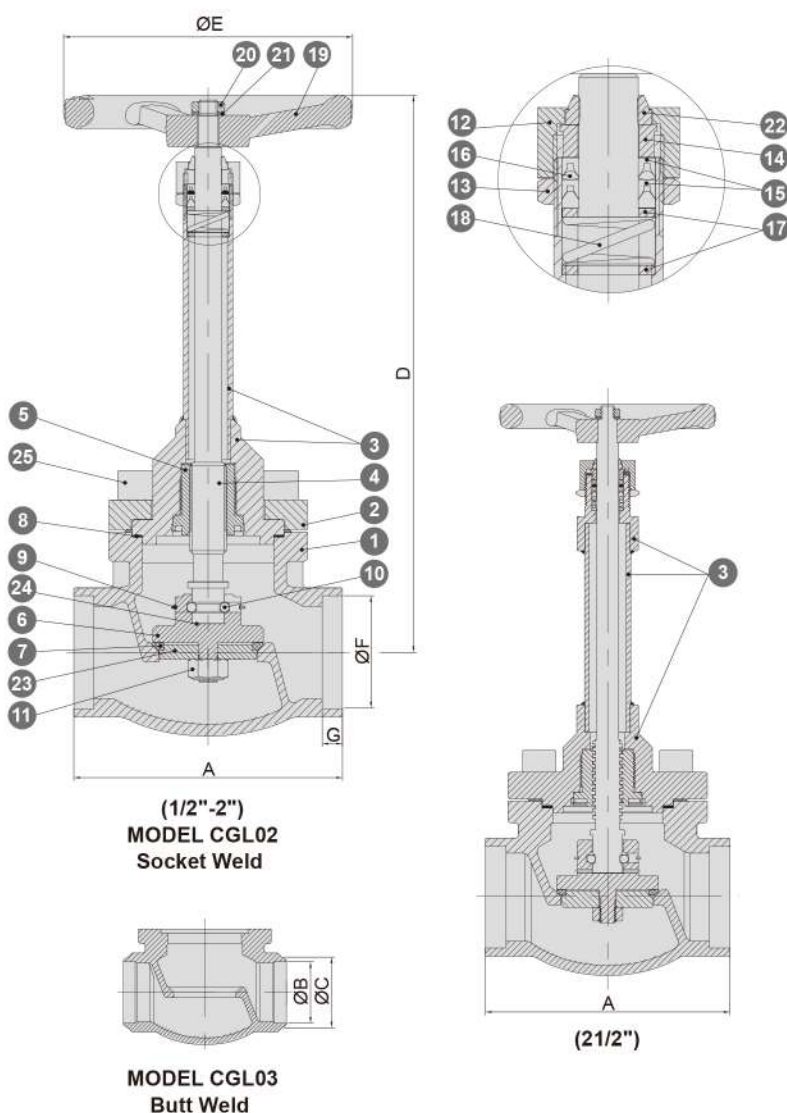

SERIES 10

SERIES 20

SERIES 30

SERIES 70

SERIES 85

SERIES 90

SERIES 95

SERIES
MPY / MP

OTHER VALVES
AND
VALVES PARTS

PRESSURE-
TEMPERATURE
RATINGS