

SERIES 20

MODEL 204-2

3-Way Ball Valve

Threaded



Pressure Rating	1000WOG
Material	ASTM A351-CF8M
Seat	TFM1600
Bore Type	Standard bore
Additional Features	<ul style="list-style-type: none"> • L-port, T-port available • ISO5211 direct mounting pad

MATERIALS LIST

N0	PART NAME	QTY	MATERIAL
1	BODY	1	CF8M
2-A	CAP	1	CF8M
2-B	CAP	2	CF8M
3	BALL	1	CF8M
4	SEAT	4/1 SETS	TFM1600
5	STEM	1	SUS316
6	THRUST WASHER	1	PTFE
7-A	PACKING	1	PTFE
7-B	PACKING	2/1 SETS	PTFE
8	STEM PACKING	1 SETS	PTFE
9	THRUST WASHER	1	TFM1600
10	GLAND BUSH	1	SUS304
11	BELLEVILLE WASHER	2	SUS304
12	STOP	1	SUS304
13	HANDLE NUT	2	SUS304
14	WASHER	1	SUS304
15	HANDLE	1	SUS304
16	HANDLE SLEEVE	1	VINYL
17	LEVER STOP	1	SUS304
18	LEVER STOP NUT	1	SUS304
19	O-RING	1	VITON

DIMENSIONS (mm)

SIZE	Ød	L	H	D	F	A	ØN	ØM	E	H1	ISO 5211		ØG
											(1)	(2)	
1/4"	11	75.7	68	9	38.3	8.2	6	6	131	36.8	F04 42	F03 36	PF.PT.NPT
3/8"	11	75.7	68	9	38.3	8.2	6	6	131	36.8	F04 42	F03 36	PF.PT.NPT
1/2"	12.5	75.7	68	9	38.3	8.2	6	6	131	36.8	F04 42	F03 36	PF.PT.NPT
3/4"	16	86.6	74	9	44.7	9.0	6	6	131	44.1	F04 42	F03 36	PF.PT.NPT
1"	20	103	94	11	50.8	11.5	6	7	184	55.1	F05 50	F04 42	PF.PT.NPT
1 1/4"	25	118.2	100	11	57.7	11.5	6	7	184	60.7	F05 50	F04 42	PF.PT.NPT
1 1/2"	32	125.8	114	14	62.6	15.1	7	9	227	75.2	F07 70	F05 50	PF.PT.NPT
2"	38	149	123	14	74.3	15.1	7	9	227	84.4	F07 70	F05 50	PF.PT.NPT

TYPE	PORT			
	1	2	3	4
T				
L				

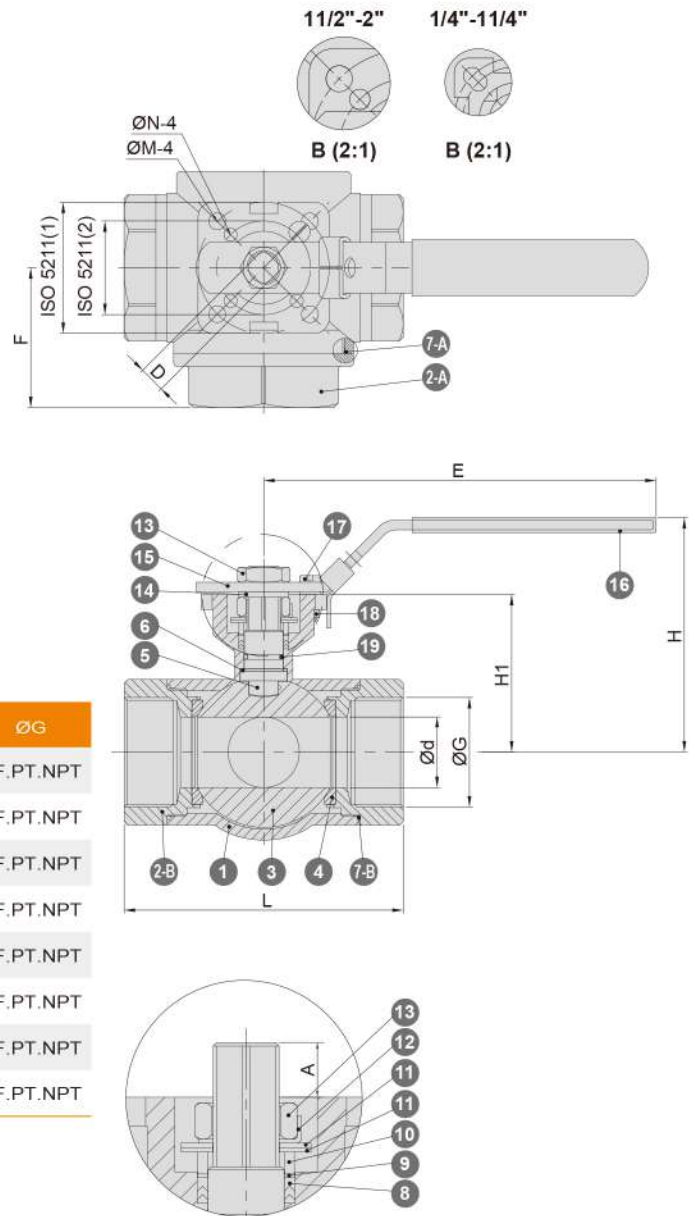

SERIES 10

SERIES 20

SERIES 30

SERIES 70

SERIES 85

SERIES 90

SERIES 95

SERIES MPY / MP

OTHER VALVES AND VALVES PARTS

PRESSURE-TEMPERATURE RATINGS