

SERIES 90

MODEL

906 / 907

3-Piece Sanitary Ball Valve
T-Clamp / Tube
(1/2" - 4")



Pressure Rating	PN64 (1/2"-2") PN50 (2 1/2"-4")
Material	EN10213-1.4408, ASTM A351-CF8M
Seat	Cavity filled PTFE, Non-cavity filled TFM1600
Bore Type	Standard bore
Additional Features	<ul style="list-style-type: none"> • Surface roughness: $Ra \leq 0.4 \mu m$ • ISO 5211 direct mounting pad • Able to add anti-static device (Ball-stem-body)

MATERIALS LIST

NO.	PART NAME	QTY	MATERIAL
1	BODY	1	1.4408(CF8M)
2	END CAP	2	1.4408(CF8M)
3	BALL	1	SUS316
4	STEM	1	SUS316
5	PACKING	2	PTFE
6	SEAT/CAVITY FILLER	2	PTFE
7	STEM SEAL	1	R.PTFE
8	V-RING PACKING	1SET	PTFE
9	BUSHING	1	50% S.S. POWDER FILLED PTFE
10	O-RING	1	VITON
11	STEM NUT	2	SUS304
12	GLAND	1	SUS304
13	BELLEVILLE WASHER	2	SUS304
14	BOLT	4-6	SUS304
15	WASHER	4-12	SUS304
16	BOLT NUT	4-12	SUS304
17	LOCK SADDLE	1	SUS304
18	WASHER	1	SUS304
19	HANDLE	1	SUS304
20	HANDLE SLEEVE	1	VINYL
21	STOP PIN	1	SUS304
22	STOP PIN NUT	1	SUS304

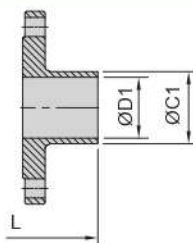

MODEL 907
Tube End

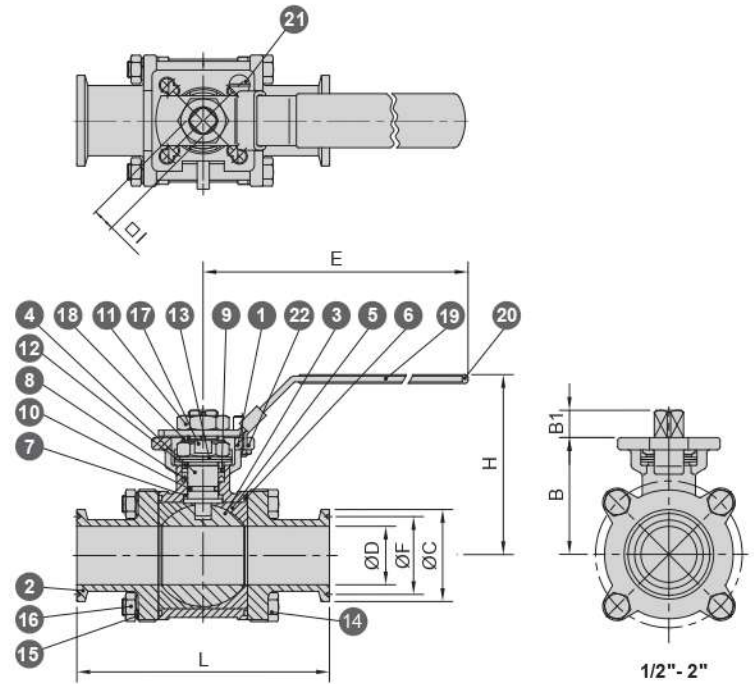

MODEL 906
Clamp End

1/2" - 2"

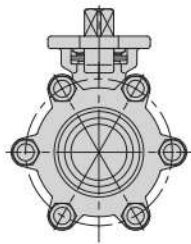

2 1/2" - 4"

DIMENSIONS (mm)

SIZE	B	B1	ØC	ØD	ØC1	ØD1	E	H	ØI	L	ISO 5211
1/2"	40.2	9	25	9.5	12.7	9.4	128	70.5	9	89.1	F03 F04
3/4"	43.4	9	25	15.9	19.05	15.75	128	73.8	9	101	F03 F04
1"	52	14	50.4	22.2	25.4	22.2	167	85.4	11	114	F04 F05
1 1/2"	65.7	15.5	50.4	35	38.1	34.8	215	99.6	14	140	F05 F07
2"	73.95	15.5	64	47.5	50.8	47.5	215	107.8	14	156	F05 F07
2 1/2"	94	16.5	77.5	60.3	63.5	60.2	322	145.7	17	197	F07 F10
3"	102	16.5	90.9	73	76.2	72.9	322	154.7	17	229	F07 F10
4"	132	21.5	118.9	97.4	101.6	97.4	320	188	22	241	F10

SERIES 10

SERIES 20

SERIES 30

SERIES 70

SERIES 85

SERIES 90

SERIES 95

SERIES
MPY / MP

OTHER VALVES
AND
VALVE PARTS

PRESSURE
TEMPERATURE
RATINGS