

SERIES 70

MODEL 705

3-Piece Ball Valve
Flanged



Pressure Rating PN64 (1/2"-2")
PN50 (2 1/2"-4")

Material EN10213-1.4408, ASTM A351-CF8M

Seat PTFE, TFM1600, 25%, 50%

Bore Type Full bore

Additional Features

- Available connections: ANSI class 150, JIS 10K, DIN PN40
- Anti-static device (Ball-stem-body)
- Able to mount actuators with extra parts

MATERIALS LIST

NO.	PART NAME	QTY	MATERIAL
1	BODY	1	1.4408 (CF8M)
2	END CAP	2	1.4408 (CF8M)
3	BALL	1	SUS316
4	STEM	1	SUS316
5	JOINT GASKET	2	PTFE
6	SEAT	2	PTFE
7	STEM SEAL	1	R.PTFE
8	V-RING PACKING	1SET	PTFE
9	BUSHING	1	50% S.S. POWDER FILLED PTFE
10	STEM NUT	2	SUS304
11	HANDLE LOCK	1	SUS304
12	HANDLE SLEEVE	1	VINYL
13	BOLT	4-6	SUS304
14	WASHER	4-12	SUS304
15	BOLT NUT	4-12	SUS304
16	GLAND	1	SUS304
17	BELLEVILLE WASHER	2	SUS304
18	LOCK SADDLE	1	SUS304
19	STOP PIN	1	SUS304

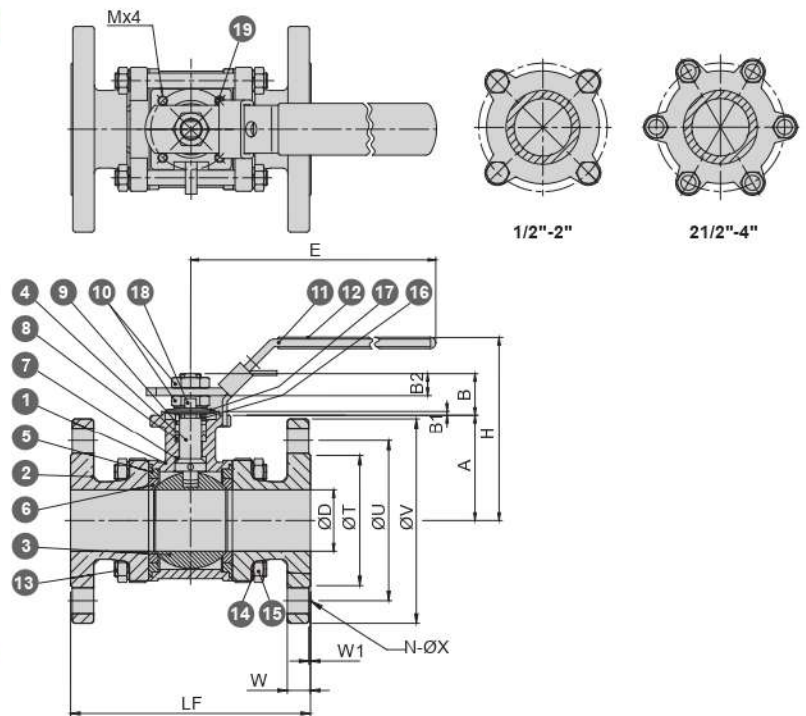

DIMENSIONS (mm)

SIZE	FLANGED	A	B	B1	B2	ØD	E	H	LF	ØT	ØU	ØV	W	W1	ØX	N	M	ISO 5211
1/2"	150 LB	37	18.8	2	9.3	15	136	72	108	35	60.4	89	11.2	1.6	16	4	M5	F03
	PN40								108	52	70	95	12	1	15			
	10K								108	52	70	95	12	1	15			
3/4"	150 LB	40.3	18.8	2	9.3	20	136	74	117	43	69.9	98.4	12.7	1.6	16	4	M5	F03
	PN40								117	58	75	105	18	2	14			
	10K								117	58	75	100	14	1	15			
1"	150 LB	50	20.4	2	10.7	25	152	92	127	50.8	79.4	108	14.3	1.6	16	4	M5	F04
	PN40								160	69	85	115	18	2	14			
	10K								127	70	90	125	14	1	19			
1 1/4"	150 LB	55.5	20.4	2	10.7	32	152	98	146	64	88.9	117.5	15.9	1.6	16	4	M5	F04
	PN40								182	78.8	100	140	18	2	18			
	10K								146	80	100	135	16	2	19			
1 1/2"	150 LB	63	26.8	3	12.6	38	190	109	165	73	98.5	127	17.5	1.6	16	4	M6	F05
	PN40								200	90	110	150	18	3	18			
	10K								165	85	105	140	16	2	19			
2"	150 LB	71.3	26.8	3	12.6	50	190	117	192	92	120.7	152.4	19.1	1.6	19	4	M6	F05
	PN40								230	106	125	165	20	3	18			
	10K								178	100	120	155	16	2	19			
2 1/2"	150 LB	89.9	33.5	3	17	65	287	147	232	104.8	139.7	177.8	22.3	1.6	19	4	M8	F07
	PN40								290	122	145	185	22	3	18			
	10K								232	120	140	175	18	2	19			
3"	150 LB	99	33.9	3	17	80	304	156	255	127	152.4	190.5	23.9	1.6	19	4	M10	F10
	PN40								310	138	160	200	24	3	18			
	10K								255	130	150	185	18	2	19			
4"	150 LB	120	33.9	3	17	100	440	178	290	157.2	190.5	228.6	23.9	1.6	19	8	M10	F10
	PN40								350	162	190	235	24	3	23			
	10K								290	155	175	210	18	2	19			

SERIES 10

SERIES 20

SERIES 30

SERIES 70

SERIES 85

SERIES 90

SERIES 95

SERIES
MPY / MP

OTHER VALVES
AND
VALVES PARTS

PRESSURE
TEMPERATURE
RATINGS